

1 GHz Trunk/Bridger Amplifiers 6PAC-M – Regular Gain (RG)

Replaces/Upgrades Phillips®/Magnavox®
Amplifiers 450/550/625/750/870 MHz Systems

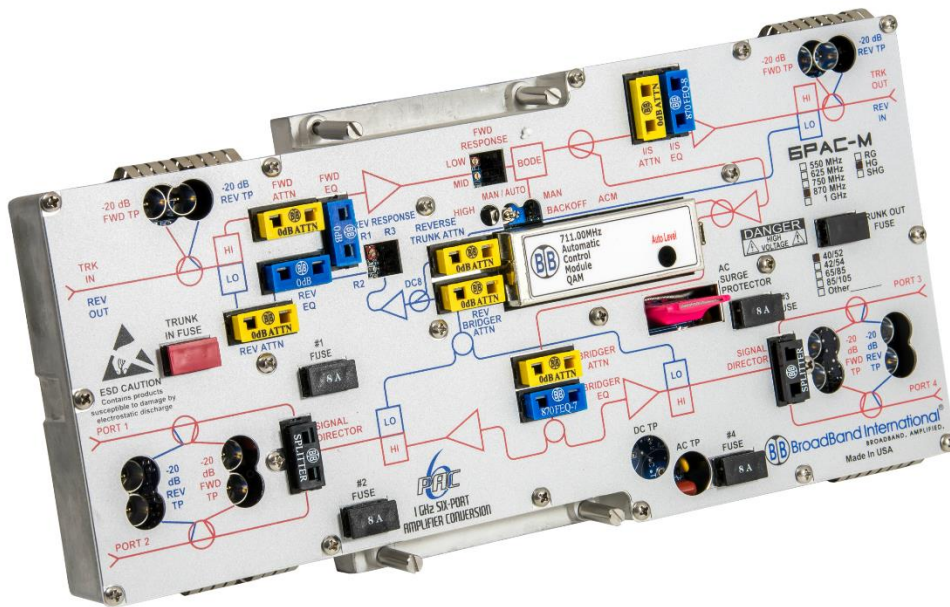

The 6PAC-M enhanced amplifier module from Broadband International® is designed to drop into any 7 or 9 Series Philips/Magnavox® 450 or 550 MHz Trunk/Bridger station housing. The forward bandwidth is up to 1 GHz and may be optimized for any bandwidth from 550 to 1 GHz. This is accomplished by alignment of the interstage plug-in bode network and by the type of cable equalizers deployed. All 6PAC modules have a very linear trunk response and very low distortions. Performance may be customized by the choice of hybrids.

Numerous analog and QAM automatic control module (plug-in) are available to meet your current and future system requirements.

Features:

- Specified bandwidth performance from 550 MHz up to 1 GHz
- Utilizes FastPac™ style plug-in equalizers and pads
- Multiple options for return path bandwidth with removable duplex filters
- Plug-in hybrid technology
- Excellent distortion and noise performance



6PAC-M – FAST-PAC™ Amplifier Conversion Performance to 1 GHz				
Analog Channels	79	95	110	Return
***6PAC-M Network Amplifier ***				
Frequency Response (dB)	+/- 0.5	+/- 0.5	+/- 0.5	+/- 0.5
Return Loss (-dB) 55-870 MHz/870 MHz to 1 GHz	16/14	16/14	16/14	16
Noise Figure (-dB)	8	8	8	12
Full Gain (dB) - Trunk	35	35	35	19
Operating Gain (dB) - Trunk	32	32	32	19
Man/Auto Gain Control Range (dB)	Auto +/-0.25 dB for +/-3/-5 input variance			
AC Hum Mod @ 10A (-dB)[15A max]	-65	-65	-65	N/A
Trunk Output Level (870/55 MHz)	44/32	44/32	44/32	35-40
Trunk Output Slope (typical @ 870 MHz)	12	12	12	N/A
Output Hybrid Technology	GaAs PD	GaAs PD	GaAs PD	Si PP
Composite Triple Beat – Trunk	86	81	78	90
Cross-Modulation - Trunk	75	73	72	82
Composite Second Order - Trunk	79	77	75	80
Bridger Gain – Ports 1 to Ports 3 and 4	39	39	39	19
Bridger Output Level (870/55 MHz)	51/39	51/39	51/39	35-40
Composite Triple Beat – Bridger	69	67	65	90
Cross-Modulation – Bridger	65	64	62	82
Composite Second Order – Bridger	69	67	65	80

Powering	Voltage/Current with BBI Internal Power Supply													
	I DC	AC Volts	90	85	80	75	70	65	60	55	50	45	40	37
Manual	1.89	AC current draw	0.92	0.95	0.99	1.04	1.08	1.14	1.23	1.32	1.43	1.59	1.8	2.11
AGC	1.95	AC current draw	0.95	0.94	0.98	1.03	1.09	1.16	1.24	1.34	1.46	1.61	1.79	2.19

6PAC-M Diagram and Ordering Information

The following Required Accessories highlighted in yellow must be ordered separately (all other pads and equalizers are provided)

BROADBAND INTERNATIONAL 6 PAC

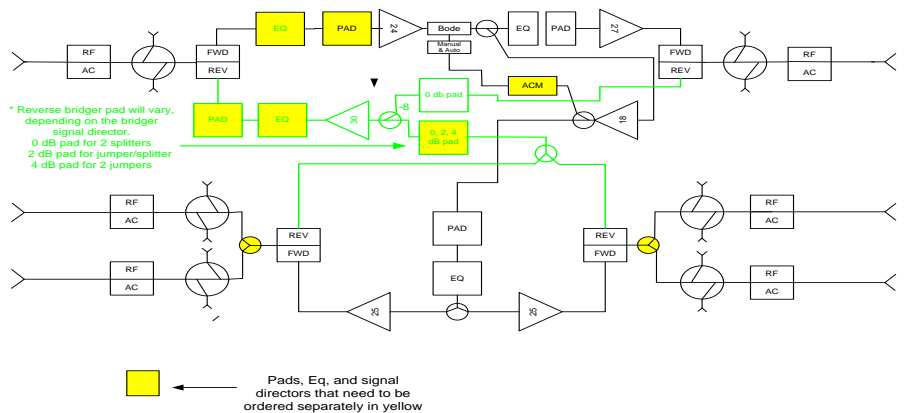

The Broadband International® 6PAC-M amplifier can be configured in many different frequencies and options. Please consult your account representative for assistance with specific plug-in options.